

Charging of Batteries with Automatic Pre-Discharge

Description

The monolithic integrated circuit, U2400B, is a bipolar circuit, designed for automatic recharging of NiCd/ NiMH batteries. It has controlled and defined charging

characteristics for different charging sequence with subsequent trickle charge operation. The long life – Memory Effect – of the recharging cell remains intact.

Features

- Three time selections: 0.5 h, 1 h or 12 h with subsequent trickle charge operation
- Battery temperature and contact monitoring
- Charging interrupt for overvoltage or excessive temperature
- Automatic pre-discharge possible
- Separate charge- and discharge outputs
- Pulse-width modulation facility of charge- and discharge current for matching to transformer or battery data
- Timer clock via mains or internal oscillator
- Reference voltage source
- LED-status output for mode indication

Case: DIP 16, SO 16

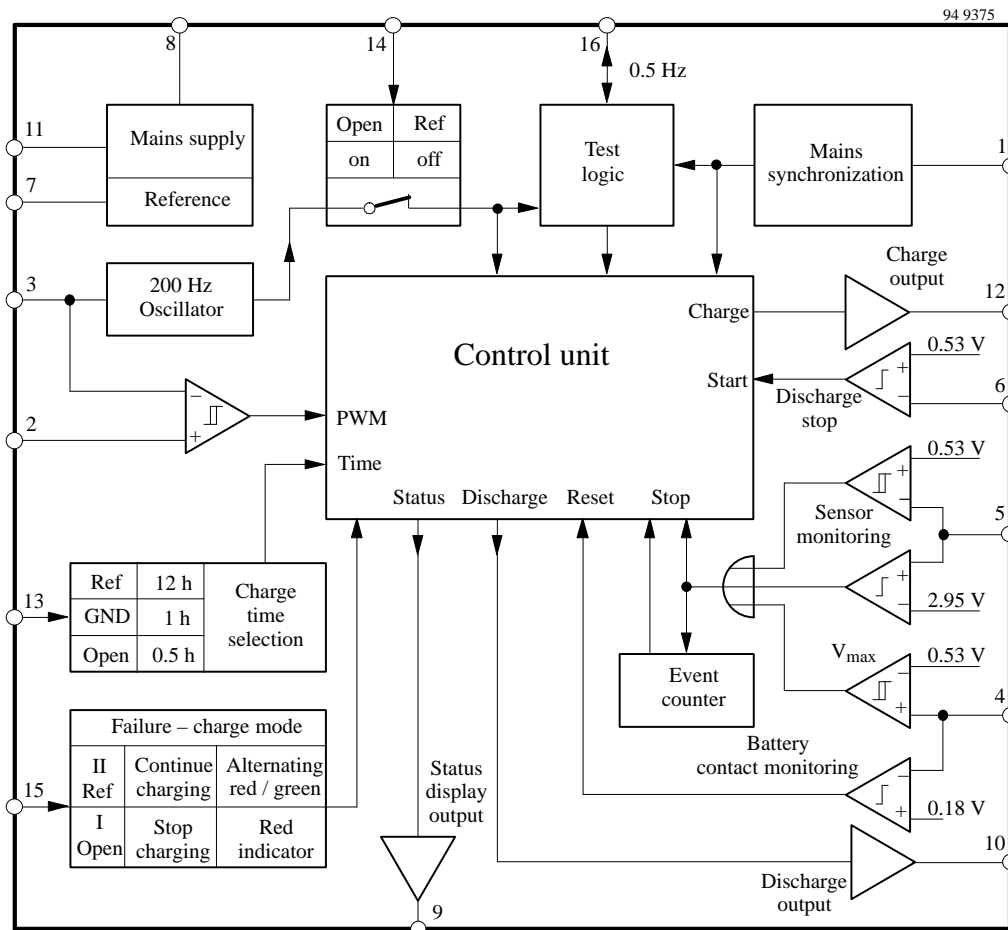

Figure 1. Block diagram

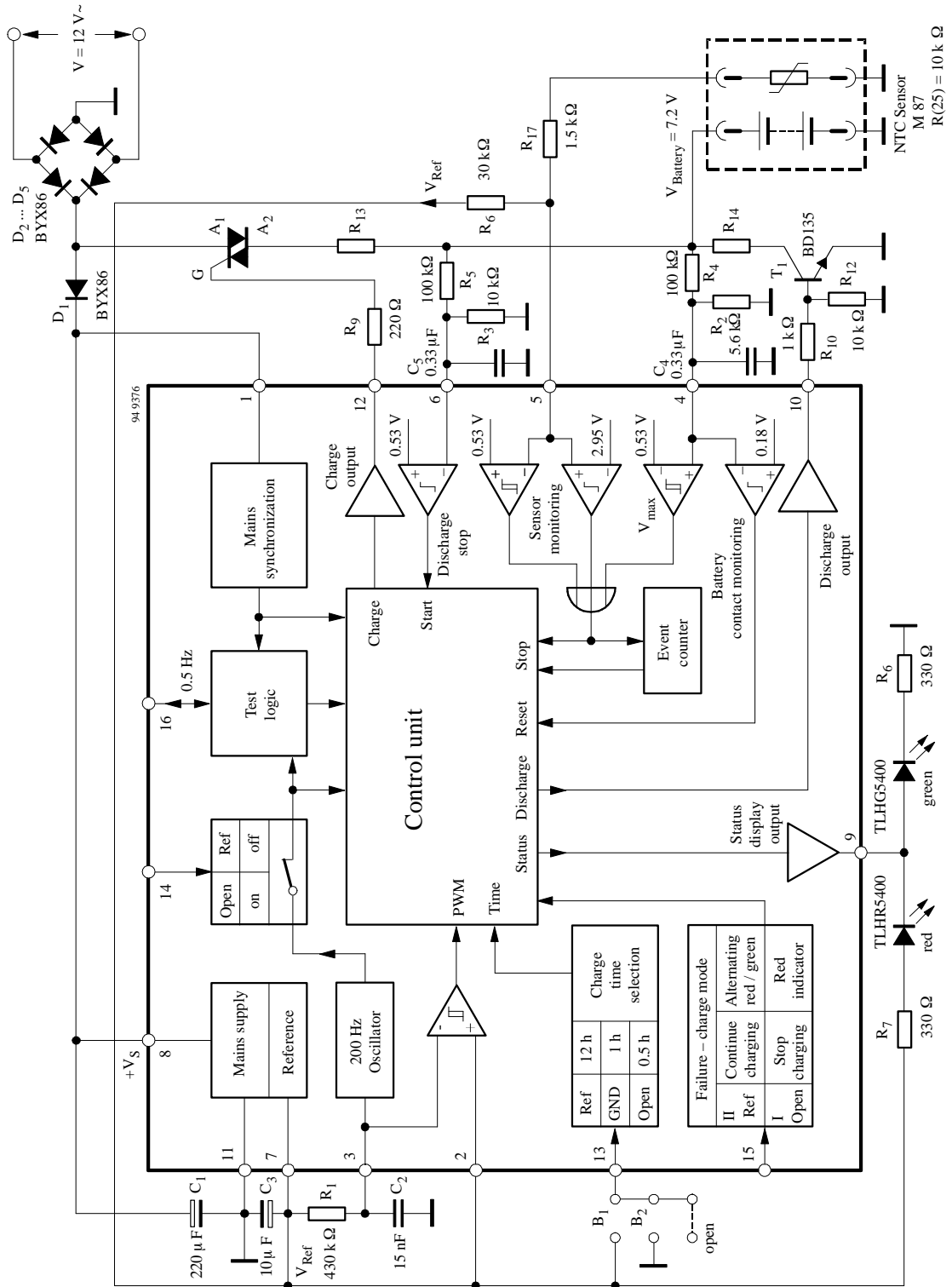

Figure 2.

General Description, Figures 2 and 3

The integrated circuit, U2400B, supports specially the controlled and defined charging of fast NiCd cells. Varieties of charging time selections i.e., standard charge (12 h), quick charge (1 h) or fast charge (0.5 h) are possible.

Before the charging begins, cell is discharged completely. In this way, the long life – Memory Effect – of the re-charging cell remains intact. Surveillance is taken over by control unit for time, thermal and voltage during the charging and switch-off when the specified capacity is attained. When switched on, the red LED connected to the display output (Pin 9) is activated if no battery is connected. When a battery is inserted with a minimum voltage of approximately 180 mV at Pin 4, the pre-

discharge phase is then started with a 2 seconds delay. Discharge output at Pin 10 is activated, which is indicated by the flashing red LED, shown in figure 5. The discharge procedure is stopped with a voltage less than 530 mV (at Pin 6). The following charge phase (charge output Pin 12 active) is indicated by the flashing green LED (Pin 9).

After the programmed charging period (Pin 13: 0.5 or 1 h continuous charge, or 12 h pulsed charge) the trickle charge phase is reached (figure 4). This trickle charge mode is indicated by the constant green LED. This means, the battery has stored the maximum possible amount of energy. The outputs – display, discharge and charge – will be set inactive (by temperature, overvoltage), and the timer clock is interrupted during all two phases and in each mode, when a limit value (Pins 4 and 5) is exceeded.

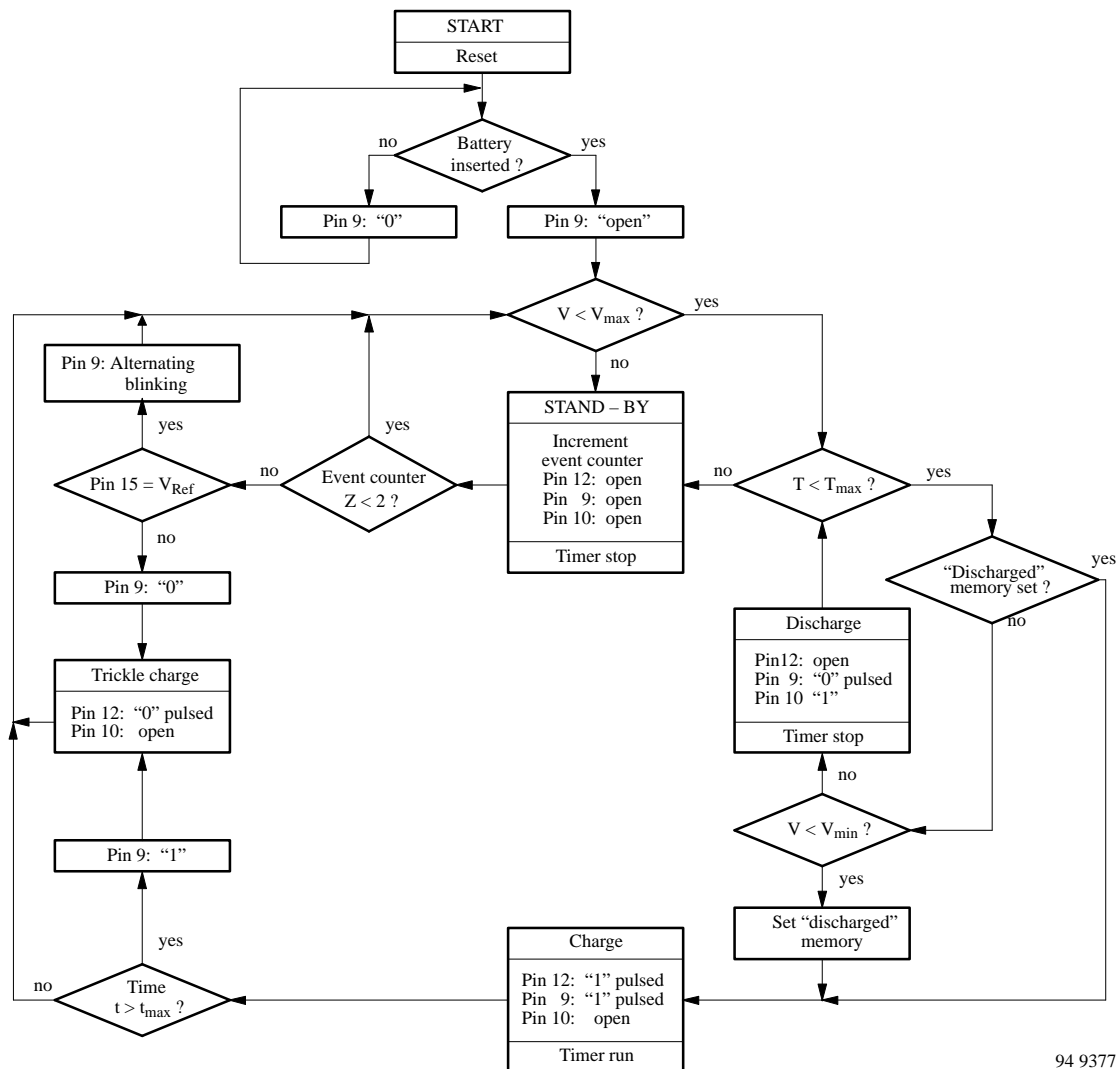

Figure 3. Flow chart

94 9377

A two-stage event counter will be incremented with each limit value violation. If the event counter stores two interruptions, subsequent behaviour is determined by the programming at Pin 15:

- An open circuit at Pin 15 means that the actual mode has to be cancelled after 2 limit value violations. This is indicated by a flashing red display.
- If the IC's internal reference voltage (Pin 7) is connected to Pin 15, only the display mode changes: alternating red-green flashing. After the limit value violation has elapsed, the IC attempts to make up for the remaining charging period so that the maximum

possible residual capacity will be made available even if a battery is already damaged.

The timer clock for programmable charging period and other internal clocks is obtained either from the internal 200 Hz oscillator, figure 6, or from the external mains synchronization (figure 7). Figure 8 shows that an external timer clock (via Pin 16) for deviating charging periods is possible. In this case the internal oscillator or mains synchronization must be activated to clock the control unit.

The negative input of a pulse-width modulator (PWM) is connected to the ramp oscillator (Pin 3). Pin 2 provides the positive input for this comparator (figure 9).

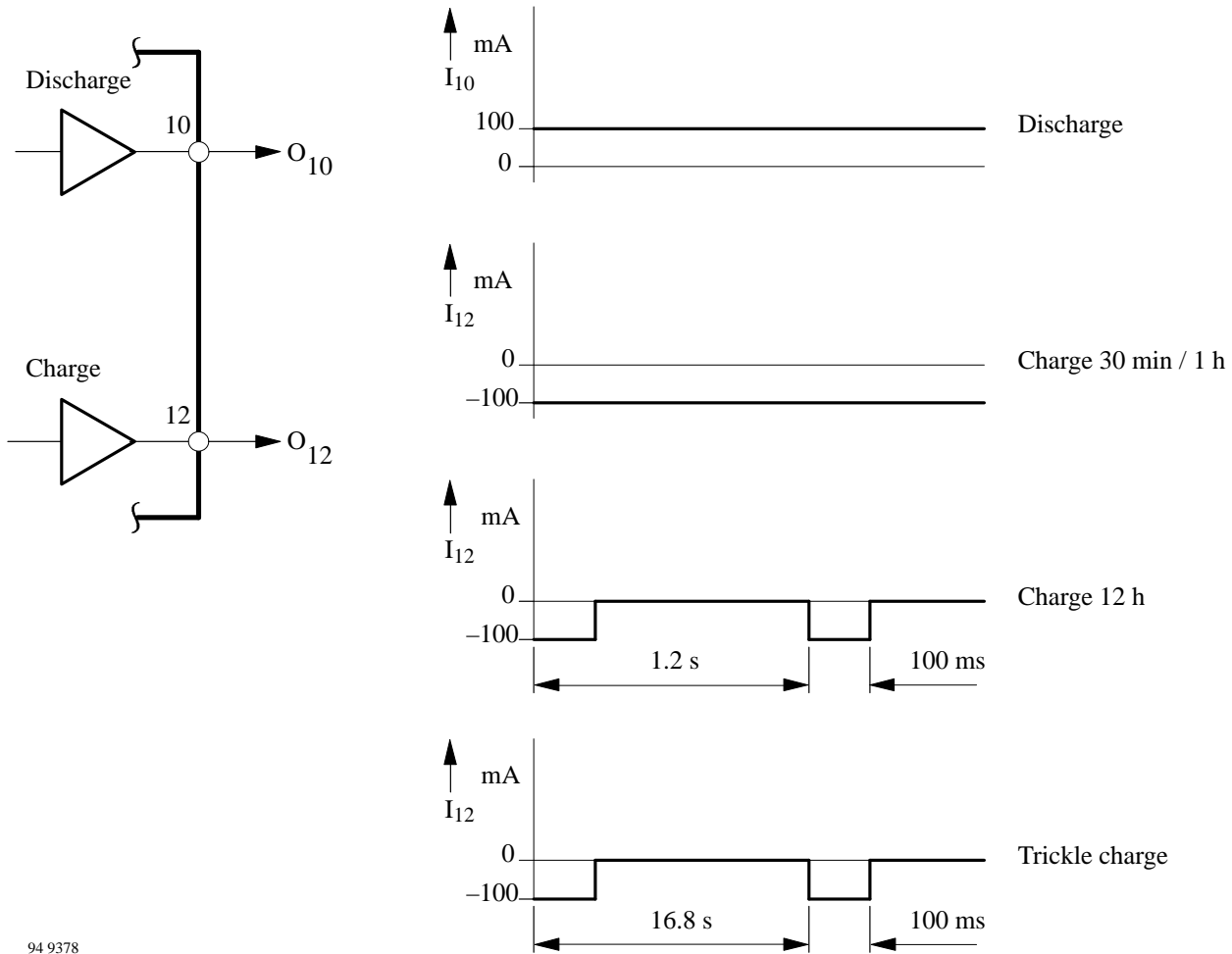

Figure 4. Discharge, charge outputs

94 9378

If a dc voltage in the range of 0.9 to 2.1 V is supplied to comparator positive input (Pin 2), the discharge and charge outputs are deactivated as soon as the oscillator's saw-tooth voltage (Pin 3) exceeds the dc voltage at Pin 2 (figures 9, 10 and 11). This pulse-width modulation effects the active discharge and charge output in each mode – discharge, charge or trickle charge. This offers the possibility of matching the r.m.s. current to various battery capacities by means of a switchable voltage divider.

Pin 14 must be connected to reference voltage Pin 7, if the internal clock signals are derived from the mains synchronization input Pin 1 with simultaneous pulse-width modulation. The oscillator can then be used deviating from 200 Hz.

As soon as a battery is removed, the red LED is active (= no contact). A total pause of approximately 2 seconds must be given between removing the charged battery and inserting a new battery to inform the IC that the inserted battery is to be charged.

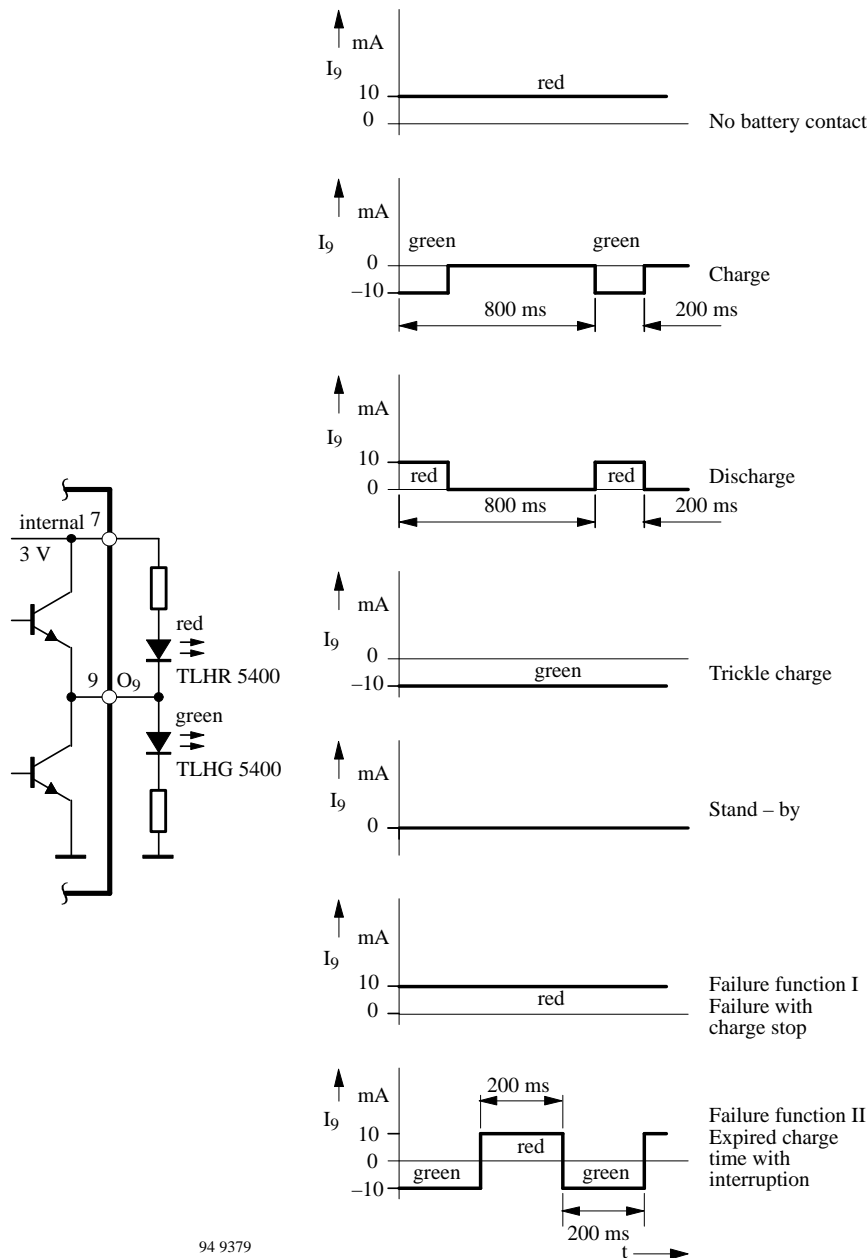

94 9379

Figure 5. Status display output

Clock generator

Timer clock can be realised either by the internal 200 Hz oscillator or with mains sync. of 50 Hz. In addition to that, there is a possibility of external timer clock input via Pin 16 (figure 8).

a) 200-Hz oscillator

Figure 6 shows the typical circuit for 200 Hz oscillator. C_1 is meant for ripple smoothing of the mains supply.

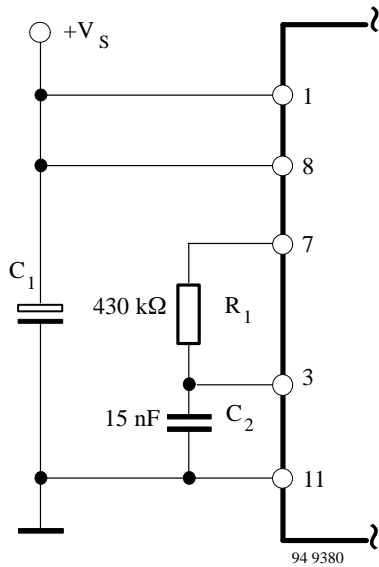

Figure 6. 200-Hz oscillator

b) Mains synchronisation

Mains synchronisation is shown in figure 7.

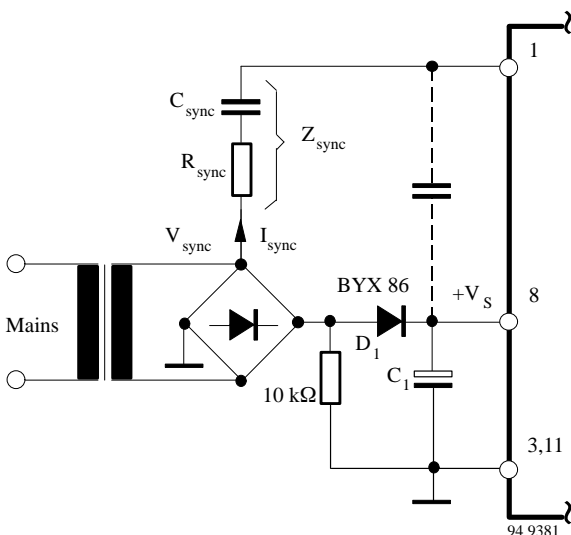

Figure 7. Mains synchronisation

Given below is the dimensioning of the circuit.

$$Z_{\text{sync}} = \sqrt{\left(\frac{1}{2 \cdot \pi \cdot f \cdot C_{\text{sync}}}\right)^2 + R_{\text{sync}}^2}$$

where f = mains frequency

$$Z_{\text{sync}(\text{min})} \geq \frac{2 \cdot \hat{V}_{\text{sync}}}{I_{\text{sync}(\text{max})}} = \frac{2 \cdot V_{\text{sync}(\text{peak})}}{10 \text{ mA}}$$

$$Z_{\text{sync}(\text{max})} \leq \frac{0.8 \text{ V}}{I_{\text{sync}(\text{min})}} = \frac{0.8 \text{ V}}{30 \text{ } \mu\text{A}}$$

i.e., $C_{\text{sync}} = 0.15 \text{ } \mu\text{F}$; $R_{\text{sync}} = 15 \text{ k}\Omega$

c) External timer clock input

For a fixed internal timing (battery contact monitoring, flashing frequency red/ green), an oscillator frequency of 200 Hz is necessary. There is a possibility of mains synchronisation via Pin 1. In case of mains synchronisation, the oscillator must be separated from the clock logic (Pin 14 connected to V_{Ref}).

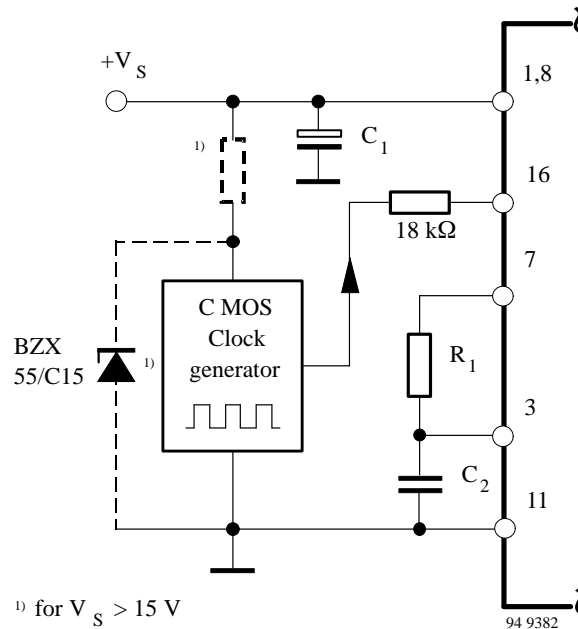

¹⁾ for $V_S > 15 \text{ V}$

Figure 8. External timer clock input, Pin 16 for different charging times

Pulse Width Modulation (PWM)

There are two separate inputs to PWM comparator. Positive lead is available at Pin 2, whereas negative lead is connected directly to the oscillator as shown in figure 9.

A dc voltage in the range of 0.9 to 2.1 V at the comparator input Pin 2, switches-off the charge and discharge outputs, when the oscillator ramp voltage at Pin 3 has a higher value than the applied voltage at Pin 2.

PWM is operating independent of discharge, charge or trickle mode. The effective current requirement for the different battery types of same voltage can be maintained by voltage ratio given below:

$$R_{11} = R_{12} \cdot \frac{V_2}{V_7 - V_2}$$

Recommended current range is 20 to 200 μ A.

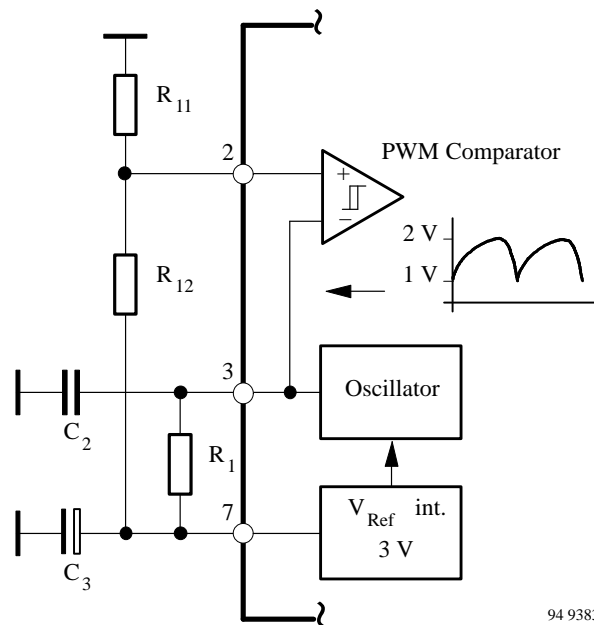

Figure 9. PWM comparator input voltage circuit for different cell capacities

In case, the internal clock signal is generated via mains synchronisation at Pin 1, then Pin 14 should be connected to Pin 7. The oscillator circuit frequency at Pin 3 can be selected now deviating from 200 Hz.

Figure 10 shows pulse diagram of PWM with respect to discharge and charge output currents, whereas figure 11 represents its ratio respecting voltage at Pin 2.

Programming Inputs

Pin 14

The internal clock signal can be derived either from the mains sync. circuit or from the autonomous oscillator. Internal oscillator clock disconnection is achieved with Pin 14 (figure 7).

Oscillator clock disconnected, when Pin 14 is connected to Pin 7 (ref.).

Oscillator clock connected, when Pin 14 is grounded (Pin 11) or open.

When oscillator clock is connected, then it is the timer clock.

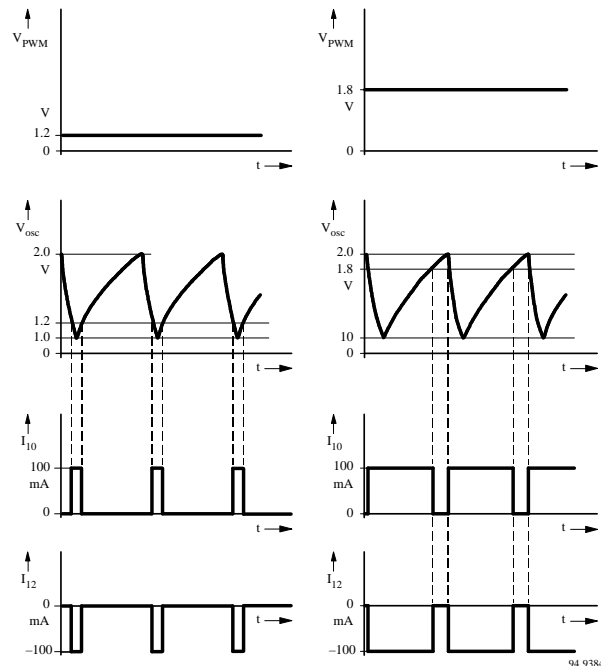

Figure 10. Pulse sequence for PWM circuit of figure 9

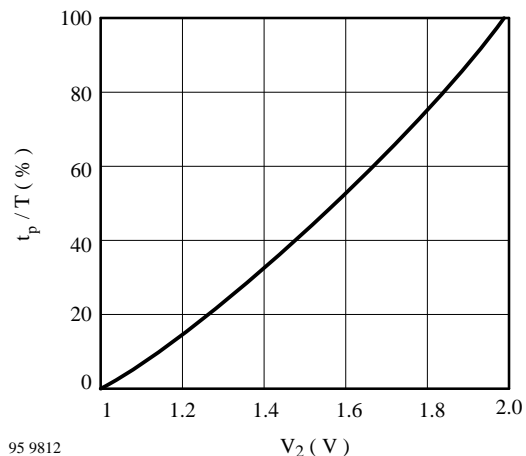

Figure 11. Duty cycle of PWM circuit of figure 9

Pin 15

There are two failure-function-possibilities.

Failure Function I $I_{15} = 0$ or 0 to 0.8 V

Trickle charge function comes into operation, if two events have occurred (temperature and/ or overvoltage).

Display mode: red blinking.

Failure Function II $V_{15} = 2.4$ to 3.0 V

The display mode will be changed after two events. Charging time will continue after each failure event.

Display mode: alternating red/ green flashing

Discharge Stop Comparator figure 12

Comparator turns off the discharge process when $V_6 \leq V_{T6}$, i.e., the specified discharge voltage of the cell is attained.

The following relationship is valid:

$$R_3 = R_5 \cdot \frac{V_{T6}}{V_B - V_{T6}}$$

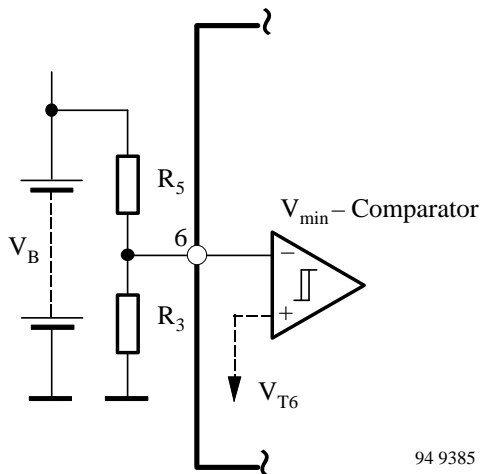

Figure 12. Comparator threshold dimensioning circuit

V_{max}-Comparator figure 13

Comparator interrupts the discharge and charge outputs when $V_4 \geq V_{T4max}$.

The following relationship is valid:

$$R_2 = R_4 \cdot \frac{V_{T4max}}{V_B - V_{T4max}}$$

Current flow for voltage divider (R_4 , R_2) should be selected so that the trickle charge (1/180 of one hour charge) should not lead to the discharge of the battery.

Take care that the input stand-by current of the comparator is less than one-tenth of divider current.

Recommended idle divider current $\geq 20 \mu\text{A}$.

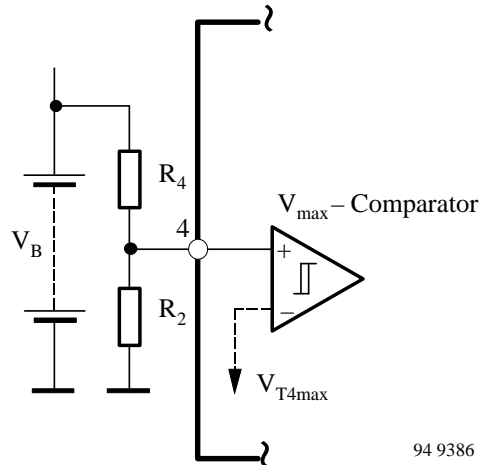

Figure 13. V_{max}-comparator circuit

Temperature comparator figure 14

This comparator interrupts the discharge and charge outputs when $V_5 \leq V_{T5min}$.

The following relationship is valid:

$$R_6 = \frac{V_{Ref} - V_{T5min}}{V_{T5min}} (R_{NTC} + R_{17})$$

R_{NTC} is calculated at 45°C .

To avoid the necessary loading of the internal reference source voltage, idle current is recommended in the range of $20 \mu\text{A}$ to 2mA .

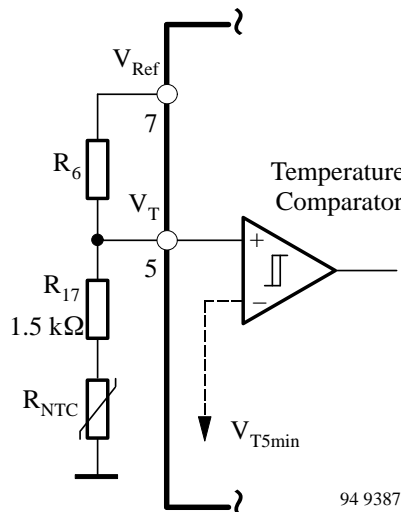

Figure 14. Temperature comparator

Absolute Maximum Ratings

Reference point Pin 11, unless otherwise specified

Parameters	Symbol	Value	Unit
Current requirement $t \leq 10 \mu\text{s}$	Pin 8 I_S	30 150	mA
Supply voltage	Pin 8 V_S	26.5	V
Output voltages			
Charge output	Pin 12 V_{12}	27	V
Discharge output	Pin 10 V_{10}	$V_S + 0.5$	V
Display output	Pin 9 V_9	6	V
Synchronisation: V_{sync} $\pm I_{\text{sync}}$	Pin 1 V_1 I_1	$V_S \pm 2$ 10	V mA
Input voltages:	Pin 2 to 6 Pin 14 to 16 v_i	6 6	V
Reference output current	Pin 7 $-I_{\text{Ref}}$	20	mA
Time selection voltage	Pin 13 V_{13}	3	V
Power dissipation $T_{\text{amb}} = 45^\circ\text{C}$ $T_{\text{amb}} = 85^\circ\text{C}$	P_{tot}	0.8 0.4	W
Storage temperature range	T_{stg}	-40 to +125	$^\circ\text{C}$
Ambient temperature range	T_{amb}	-10 to +85	$^\circ\text{C}$

Thermal Resistance

Parameters	Symbol	Value	Unit
Junction ambient DIP 16 SO 16 on PC board SO 16 on ceramic	R_{thJA}	120 180 100	K/W

Electrical Characteristics

 $V_S = 5 \text{ V}$, $T_{\text{amb}} = 25^\circ\text{C}$, reference point Pin 11, unless otherwise specified

Parameters	Test Conditions / Pins	Symbol	Min.	Typ.	Max.	Unit
Supply						
Current consumption	without load Pin 8	I_S	1.5		5.0	mA
Voltage range	Pin 8	V_S	5.0		25.0	V
Voltage limitation	$I_S = 10 \text{ mA}$ Pin 8	V_S	26.5		29.5	
Reference voltage	$I_7 = 0 \text{ to } 5 \text{ mA}$ Pin 7	V_{Ref}	2.82	3.0	3.18	V
Max. reference current	Pin 7	$-I_{\text{Ref}}$			10	mA
Control outputs						
Discharge current	Pin 10	$-I_{10}$	100		135	mA
Charge current	Pin 12	$+I_{12}$	100		135	
Saturation voltage						
Charge output, $I_{12} = 100 \text{ mA}$	Pin 12-11	V_{sat}	0.8		2.5	V
Discharge output, $I_{10} = -100 \text{ mA}$	Pin 10-8		0.8		2.5	

U2400B

TEMIC

TELEFUNKEN Semiconductors

Parameters	Test Conditions / Pins	Symbol	Min.	Typ.	Max.	Unit
Oscillator						
Pin 3						
Oscillator frequency	$C_2 = C_{osc} = 15 \text{ nF}$ $R_1 = R_{osc} = 430 \text{ k}\Omega$	f_{osc}		200		Hz
Low saw-tooth threshold		V_{T3min}		1.0		V
Upper saw-tooth threshold		V_{T3max}		2.0		V
Comparators						
Discharge stop	Pin 6	V_{T6}		525±5%		mV
Overvoltage	Pin 4	V_{T4max}		525±5%		
Hysteresis	Pin 4	V_{hyst}		15		mV
Battery contact monitoring	Pin 4	V_{T4min}	140		200	mV
Sensor temperature voltage	Pin 5	V_{T5min}		525±5%		mV
Hysteresis	Pin 5	V_{hyst}		15		mV
Open wire voltage	Pin 5	V_{T5max}	$V_{7-0.25}$		$V_{7-0.02}$	V
PWM-Comparator input voltage range	Pin 2	V_2	0.9		3.0	V
PWM-Comparator-Hysteresis	Pin 2	$V_2 \text{ hyst}$	18		40	mV
Charge time $f = 50 \text{ Hz (mains) or}$ $200 \text{ Hz (oscillator)}$	Pin 13 = open Pin 13 = ground Pin 13 = +3 V	t		30 1 12		min h h
Status output						
Output current	Pin 9	$\pm I_0$	8		15	mA
Saturation voltage	Pin 9-11	V_{sat}			0.5	V
	Pin 9-7	$-V_{sat}$			0.5	

Applications

Quick charge for NiCd-batteries with PWM method

Figure 15 describe the current regulations with PWM. Mean value of the charge current for the battery which is created across power transistor T_2 is so dimensioned that it is independent of supply and battery voltage. For the purpose of regulation, load current is obtained via resistor $R_{20} = 0.2 \Omega$, whose voltage drop serves as actual value for the operation amplifier. It is however recommended to use PNP-differential input stage due to its relatively low loss of power across the shunt resistance ($P = 0.2 \text{ W}$, @ 200 mV with 1 A charge current).

GND is the negative supply for operational amplifier

whereas the reference point for other components of the IC is different i.e., positive shunt drop voltage. Current set point is given across the voltage divider R_{15}/P_1 whereas the actual value across R_{18} with a common point, the resistance R_{20} .

The output voltage of operational amplifier delivers the voltage for PWM-control at Pin 2. Current regulation acts only on charge current, whereas discharge current is specified by R_{14} .

Maximum and minimum voltage adjustment for variety of cells (batteries) can be calculated with R_4/R_2 and R_5/R_3 ratios.

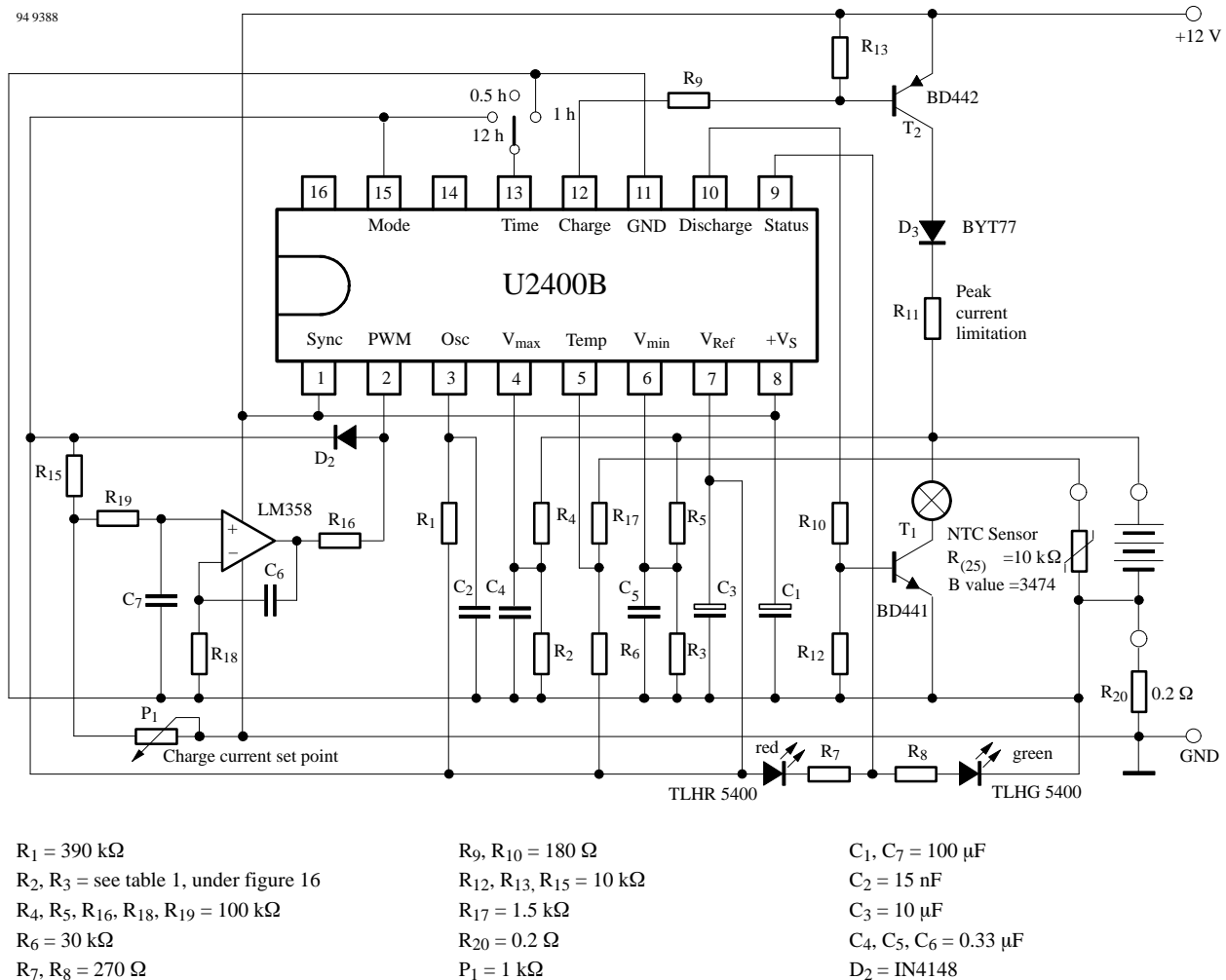
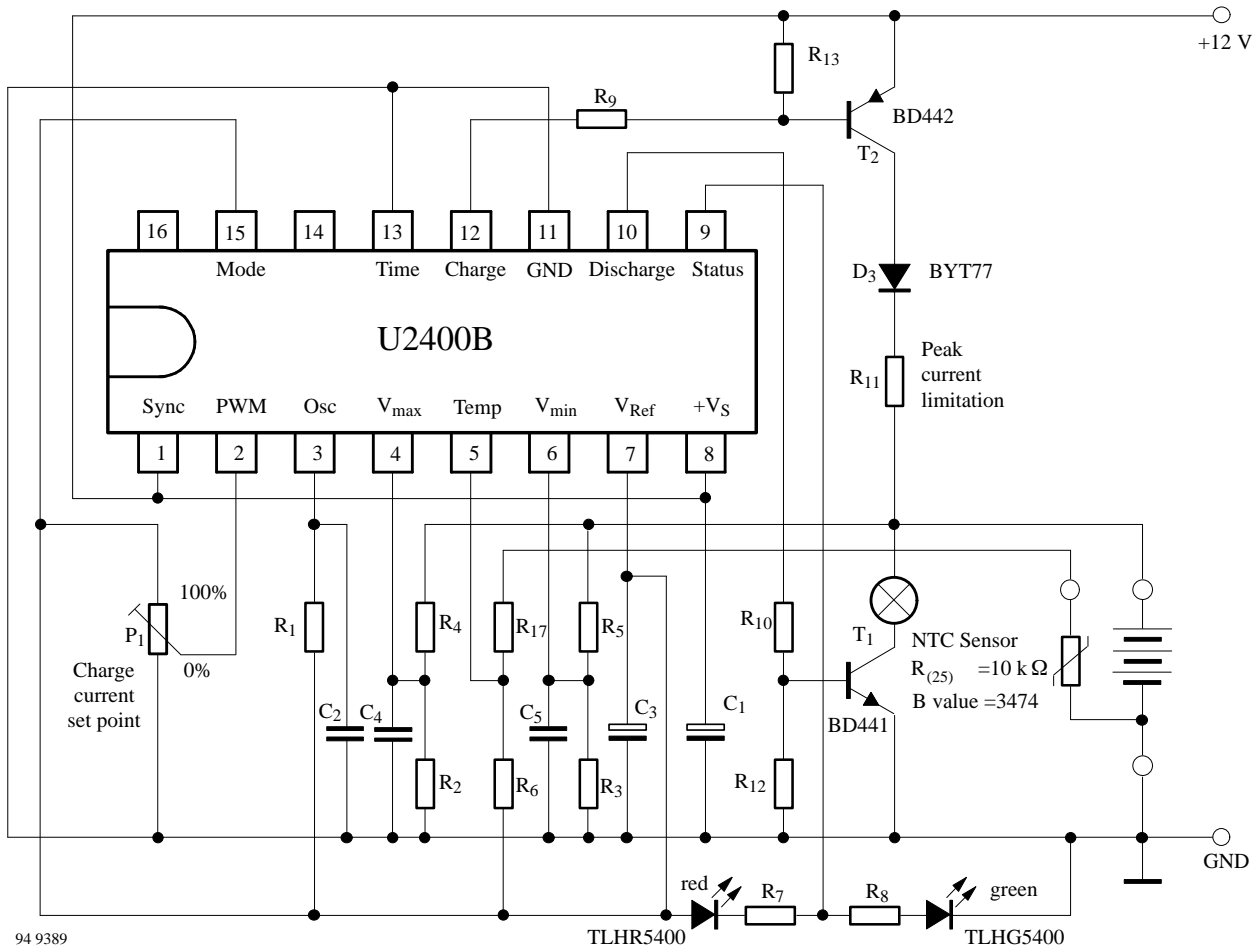

Figure 15.

- Charge current regulation
- Automatic pre-discharge
- Charge time: 0.5 h, 1 h, 12 h
- Temperature monitoring
- Status indication



- $R_1 = 390 \text{ k}\Omega$
 $R_2, R_3 = \text{see table 1}$
 $R_4, R_5 = 100 \text{ k}\Omega$
 $R_6 = 30 \text{ k}\Omega$
 $R_7, R_8 = 270 \Omega$
- $R_9, R_{10} = 180 \Omega$
 $R_{12}, R_{13} = 10 \text{ k}\Omega$
 $R_{17} = 1.5 \text{ k}\Omega$
 $P_1 = 10 \text{ k}\Omega$
- $C_1 = 100 \mu\text{F}$
 $C_2 = 15 \text{ nF}$
 $C_3 = 10 \mu\text{F}$
 $C_4, C_5 = 0.33 \mu\text{F}$

Figure 16.

- Automatic pre-discharge
- Charge time 1 h
- Temperature monitoring
- Status indication

Table 1. Resistances R_2 and R_3 dimensioning for figures 15 and 16

Cell Quantity	1	2	3	4	5	6	7
R_2	47 kΩ	18 kΩ	10 kΩ	8.2 kΩ	6.2 kΩ	5.6 kΩ	4.7 kΩ
R_3	130 kΩ	39 kΩ	24 kΩ	15 kΩ	12 kΩ	10 kΩ	8.2 kΩ

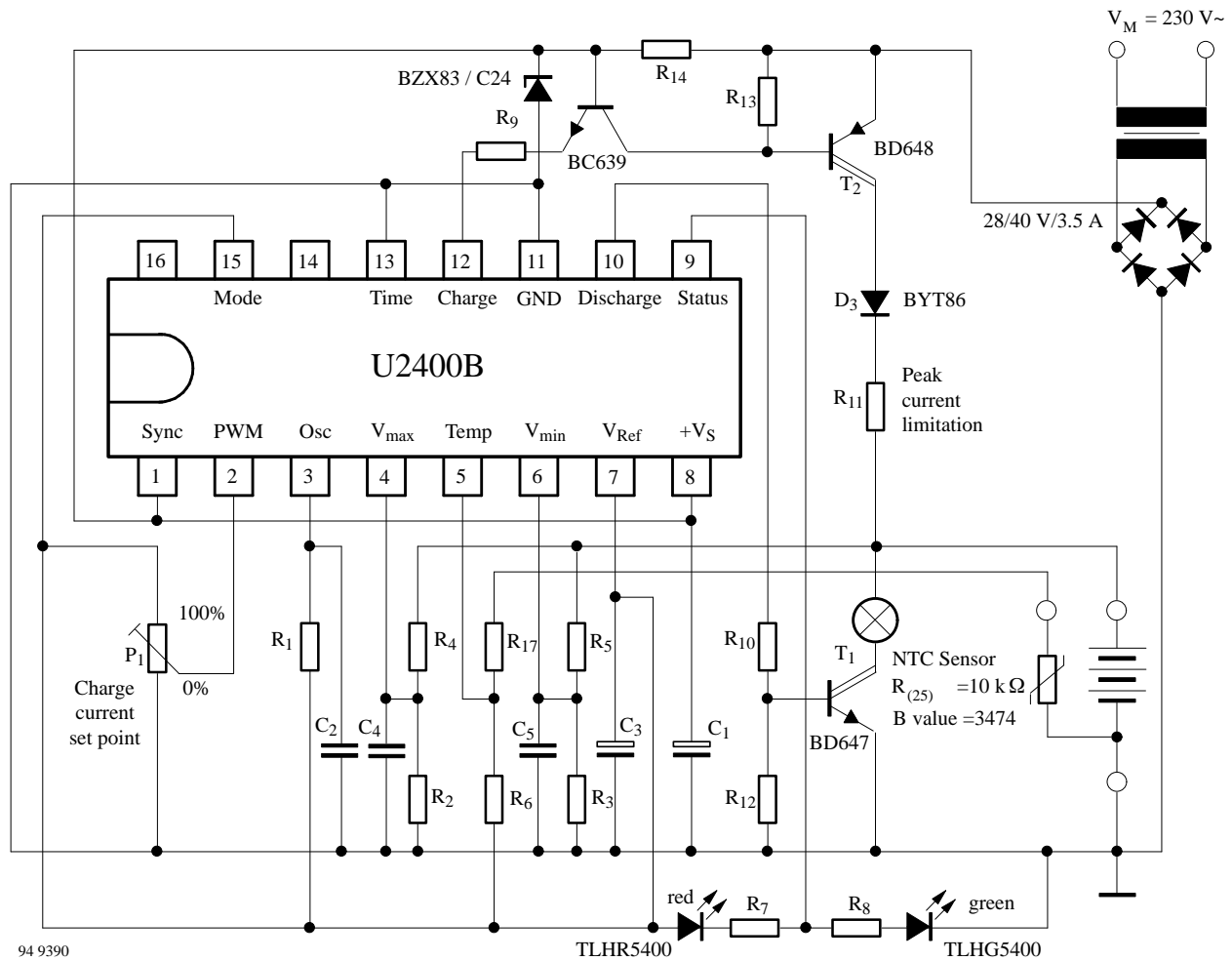

94 9390

$R_1 = 510 \text{ k}\Omega$
 $R_2, R_3 = \text{see table 2}$
 $R_4, R_5 = 100 \text{ k}\Omega$
 $R_6 = 30 \text{ k}\Omega$
 $R_7, R_8 = 270 \Omega$

$R_9, R_{10} = 2.2 \text{ k}\Omega / 0.5 \text{ W}$
 $R_{12}, R_{13} = 10 \text{ k}\Omega$
 $P_1 = 10 \text{ k}\Omega$
 $R_{14} = 220 \Omega / 1 \text{ W}$
 $R_{17} = 1.5 \text{ k}\Omega$

$C_1 = 470 \mu\text{F}$
 $C_2 = 22 \text{ nF}$
 $C_3 = 10 \mu\text{F}$
 $C_4, C_5 = 0.33 \mu\text{F}$

Figure 17.

- Charge voltage higher than IC supply
- Charge time 2 h
- Pre-discharge function
- Temperature monitoring

Table 2. Resistances R_2 and R_3 dimensioning

Cell quantity	20	30
R_2	1.5 k Ω	1.0 k Ω
R_3	2.2 k Ω	1.5 k Ω

U2400B

TEMIC

TELEFUNKEN Semiconductors

Dimensions in mm

Package: DIP 16

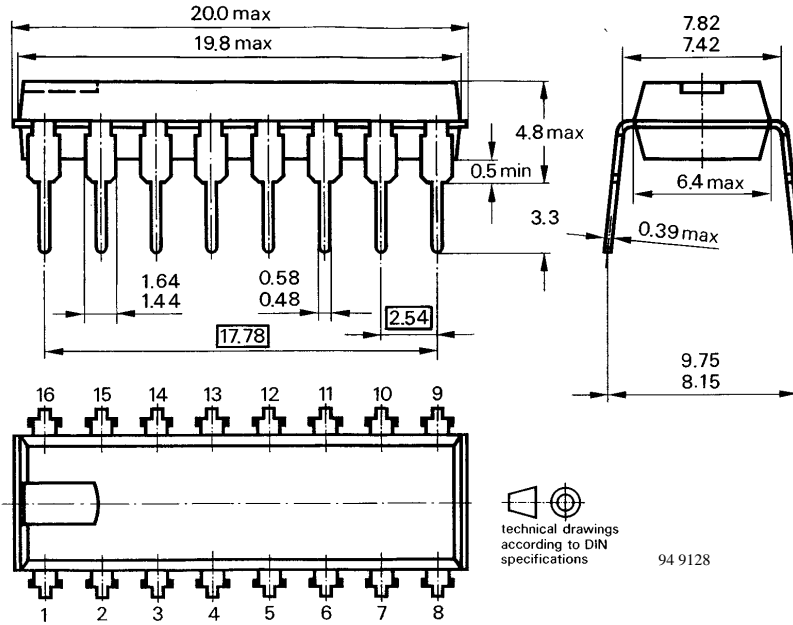

Package: SO 16

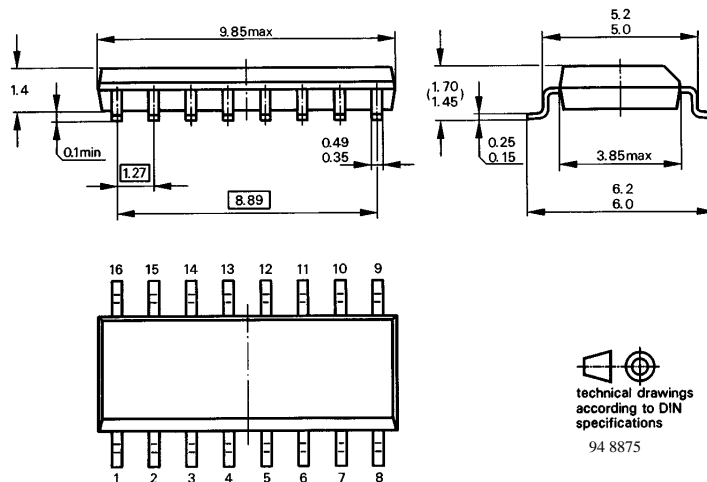

Ozone Depleting Substances Policy Statement

It is the policy of **TEMIC TELEFUNKEN microelectronic GmbH** to

1. Meet all present and future national and international statutory requirements.
2. Regularly and continuously improve the performance of our products, processes, distribution and operating systems with respect to their impact on the health and safety of our employees and the public, as well as their impact on the environment.

It is particular concern to control or eliminate releases of those substances into the atmosphere which are known as ozone depleting substances (ODSs).

The Montreal Protocol (1987) and its London Amendments (1990) intend to severely restrict the use of ODSs and forbid their use within the next ten years. Various national and international initiatives are pressing for an earlier ban on these substances.

TEMIC TELEFUNKEN microelectronic GmbH semiconductor division has been able to use its policy of continuous improvements to eliminate the use of ODSs listed in the following documents.

1. Annex A, B and list of transitional substances of the Montreal Protocol and the London Amendments respectively
2. Class I and II ozone depleting substances in the Clean Air Act Amendments of 1990 by the Environmental Protection Agency (EPA) in the USA
3. Council Decision 88/540/EEC and 91/690/EEC Annex A, B and C (transitional substances) respectively.

TEMIC can certify that our semiconductors are not manufactured with ozone depleting substances and do not contain such substances.

We reserve the right to make changes to improve technical design and may do so without further notice.

Parameters can vary in different applications. All operating parameters must be validated for each customer application by the customer. Should the buyer use TEMIC products for any unintended or unauthorized application, the buyer shall indemnify TEMIC against all claims, costs, damages, and expenses, arising out of, directly or indirectly, any claim of personal damage, injury or death associated with such unintended or unauthorized use.

TEMIC TELEFUNKEN microelectronic GmbH, P.O.B. 3535, D-74025 Heilbronn, Germany
Telephone: 49 (0)7131 67 2831, Fax number: 49 (0)7131 67 2423